



# Power Management

## PMICs

- PMICs

## Power Conversion

- Power Modules
- Switching Regulators
- Switching Controllers
- DDR Termination
- LDOs & Regulators

## System Controls

- USB Power Switches
- Voltage References
- Supervisors

## LED Lighting

- Switching Regulators



## Table of Contents

Power Management Portfolio.....	3
PIMCs .....	4
PMICs.....	4
PMIC Solutions for MaxLinear SoCs.....	6
Power Conversion.....	8
Power Modules.....	8
Power Solutions for MaxLinear SoCs.....	9
Step-Down Switching Regulators .....	10
Switching Controllers.....	11
DDR Termination.....	12
LDOs & Regulators.....	12
System Controls.....	14
USB Power Switches.....	14
Voltage References.....	14
Supervisors.....	15
LED Lighting.....	16
Switching Regulators.....	16

# Power Management Portfolio

PMICs		
Triple PMICs	Quad PMICs	
XR77103	XRP7704	XRP7740
XR77103-A0R5	XRP7714	MxL7704-B
XR77103-A1R0		
XR77103-G1R2		
XR77103-MoCA		

Power Conversion								
Power Modules	Step-Down Switching Regulators			Switching Controllers	Linear			
	>22V	>6V	<6V	Step-Down	LDOs & Regulators			DDR Termination
XR79103	SP7650	XR76108	SP6669	SP6132H	LP2951	SPX1117	SPX2941	XRP2997
XR79106	XR76203	XR76112	XRP6658	SP6134H	SP6205	SPX1582	SPX2945	
XR79110	XR76205	XR76117		XRP6141	SP6213	SPX1585	SPX2954	
XR79115	XR76208	XR76121		XR75100		SPX1587	SPX3819	
XR79120		MxL76125				SPX2815	SPX3940	
XR79203						SPX29152	SPX5205	
XR79206						SPX29300	XRP29302	
MxL7218						SPX29301	XRP6272	
MxL7225						SPX29302		
MxL7225-1								

System Controls						
Power Switches		Voltage References		Supervisors		
Single	Dual					
SP2525A	SP2526A	SPX1431	SPX2431	SP691A	SP705	SP706
		SPX385		SP706R	SP706S	SP706T
		SPX432		SP707	SP708	SP708S
				SP708T	SP809	
				SP813L		

LED Lighting
Switching Regulators
Step-Down
XRP7613

MaxLinear's PMICs range from simple 3 output devices in tiny 4x4mm packages to I2C programmable devices with as many as 5 outputs scalable to outputs of greater than 30Amps. PMICs reduce system complexity with fewer components. Those with I2C interfaces offer dynamic voltage scaling, sequencing configurability, fault management and telemetry. Easy to use configuration software tools speed development and significantly reduce overall time to market. MaxLinear also offers optimized PMIC solutions for our G.hn chipset and MoCA SoCs.

**Applications**

- G.hn and MoCA Networking Solutions
- 5G RRUs and AAS Telecommunications Equipment
- FPGA, DSP and ASIC power systems
- Industrial and embedded systems

**PMICs**

Part Number	Ch.	Gate Drive Up/Down (Ω)	VIN MIN (V)	VIN MAX (V)	VOUT MIN (V)	Internal MOSFETs	IQ (mA)	Programmable Frequency Range (MHz)	NVM Technology	Package	Features
XR77103	3	3A 2A 2A	4.5	14	0.8	Yes	1.5	0.3 to 2.2	EEPROM	TQFN-32	<ul style="list-style-type: none"> <li>▪ Synchronous</li> <li>▪ UVLO, OTP, soft-start</li> <li>▪ Light load efficiency - PFM and PWM mode</li> <li>▪ Overcurrent and output overvoltage protection</li> <li>▪ I<sup>2</sup>C reconfigurable</li> </ul>
XR77103-MoCA	3	3A 2A 2A	0.9 1.8 3.3	0.9 1.8 3.3	4.5	Yes	1.5	0.560	Pre-programmed	TQFN-32	<ul style="list-style-type: none"> <li>▪ Synchronous</li> <li>▪ UVLO, OTP, soft-start</li> <li>▪ Light load efficiency, PFM and PWM mode</li> <li>▪ Overcurrent and output overvoltage protection</li> </ul>
XR77103-A1R0	3	3A 2A 2A	0.8	6				1			
XR77103-AOR5	3	3A 2A 2A	0.8	6				0.5			
XR77103-G1R2	3	3A 2A 2A	1.1 1.5 3.3	1.1 1.5 3.3				1.140			
MxL7704-B	4	1.5A 1.5A 2.5A 4A	4.5	5.5	3.0 1.3 0.8 0.6	No	8	1 to 2.1	Factory Only	QFN32	<ul style="list-style-type: none"> <li>▪ Two configurable power good outputs</li> <li>▪ LDO and 2-input 8-bit ADC</li> <li>▪ Temperature monitoring</li> <li>▪ Supported by Excel configuration tool</li> </ul>
XRP7713	3	6/3	4.75	25	0.9	No	9	0.3 to 1.5	OTP	TQFN-32	<ul style="list-style-type: none"> <li>▪ Digital PWM controller</li> <li>▪ Faults, warnings, sequencing, GPIOs and PID compensation are all I<sup>2</sup>C reconfigurable</li> <li>▪ 3.3V or 5V selectable LDO</li> <li>▪ Integrated MOSFET drivers</li> </ul>
XRP7714	4									TQFN-40	
XRP7704	4	-/-	6.5	20	0.9	No	9	0.3 to 1.5	OTP	TQFN-40	
XRP7740	4	3/1.8									

**Configurable PMIC for FPGAs, DSPs, & μPs**

Universal PMIC features:

- Sequencing engine with PGOOD handling
- Integrated 8-bit ADC provides telemetry and flexibility



**MAXLINEAR** MXL7704 Five Output Universal PMIC with I2C Interface and 8-bit ADC

MxL7704 Configuration Tool Revision 2.0

Device Name: MXL7704

Number of Channels: 5 Channels

VIN Min: 4.25 V, 5.50 V, VIN Max

Buck Switching Frequency: 1.0 MHz

**Output Voltage**

Buck 1: 3.46 V V => See DS for LOW VIN

Buck 2: 1.80 V

Buck 3: 1.50000 V

Buck 4: 0.90000 V

LDO: 3.34 V

**Sequencing Group**

3.0V to 3.0V	Max=1.5A	Buck 1	2	ON	Buck 1
1.3V to 1.3V	Max=1.5A	Buck 2	3	ON	Buck 2
0.8V to 1.8V	Max=0.5A	Buck 3	1	ON	Buck 3
0.8V to 1.4V	Max=6A	Buck 4	0	ON	Buck 4
1.5V to 3.0V	Max=0.1A	LDO	2	ON	LDO

SEQ\_EN Group Assign: 1

**POWER SOFT START SEQUENCING**

**PG1 Routing**

Buck 1	ON	Buck 1
Buck 2	OFF	Buck 2
Buck 3	OFF	Buck 3
Buck 4	OFF	Buck 4
LDO	OFF	LDO

**PG2 Routing**

Buck 1	OFF	Buck 1
Buck 2	ON	Buck 2
Buck 3	OFF	Buck 3
Buck 4	OFF	Buck 4
LDO	OFF	LDO

**PG Routing Sequence**

**Fault Action and Shutdown Settings**

Chip Fault	ON
Soft Off	ON
70-Ohm Discharge	ON

**MxL7704 Register Settings (Slave Address = 7'h2D)**

MxL7704 Registers	Address (HEX)	Data (HEX)	Read From MxL7704(HEX)
Voltage LDO	10	A7	A5
Voltage Buck 1	11	AD	A5
Voltage Buck 2	12	5A	5A
Voltage Buck 3	13	F0	D8
Voltage Buck 4	14	90	C0
Buck Group	15	1E	F9
LDO Group/CH_EN	16	9F	1F
PG1 Routing	17	42	64
PG2 Routing	18	04	1A
Fault Actions/Freq	19	E4	E9

MxL7704-B Excel Configuration Tool

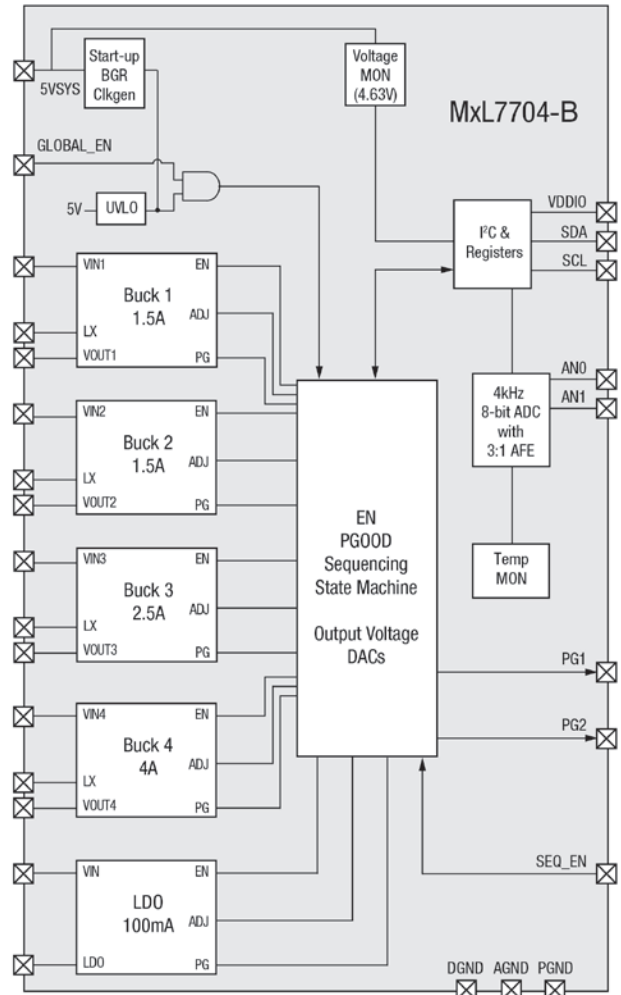

MxL7704-B Functional Block Diagram

PMIC Solutions for MaxLinear SoCs

MaxLinear has configured two versions of the XR77103 as dedicated solution for our MoCA and G.hn SoCs. These solutions have been qualified together with the SoC and Ethernet PHY peripherals to ensure the optimal signal path performance. Having a proven power solution minimizes risk and speeds time to market.

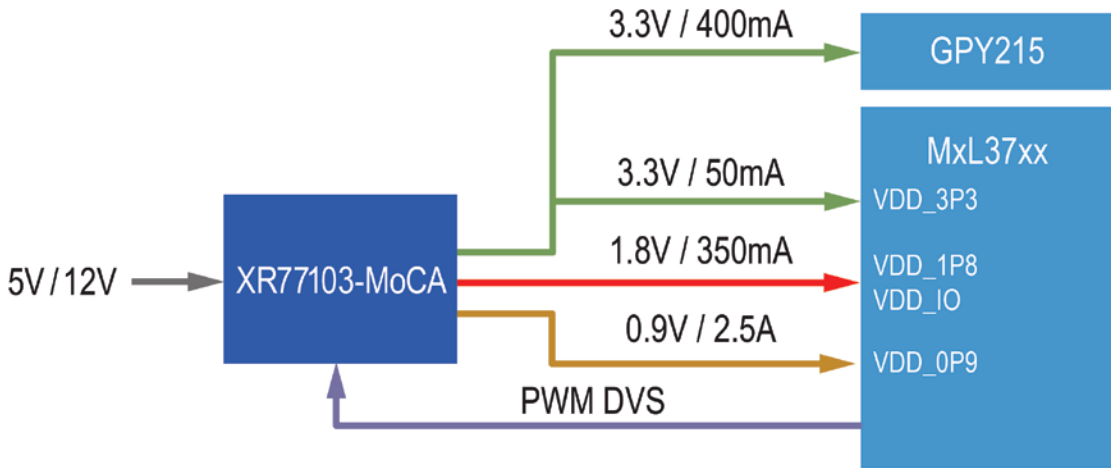

MoCA SoC and Ethernet PHY Power Solution

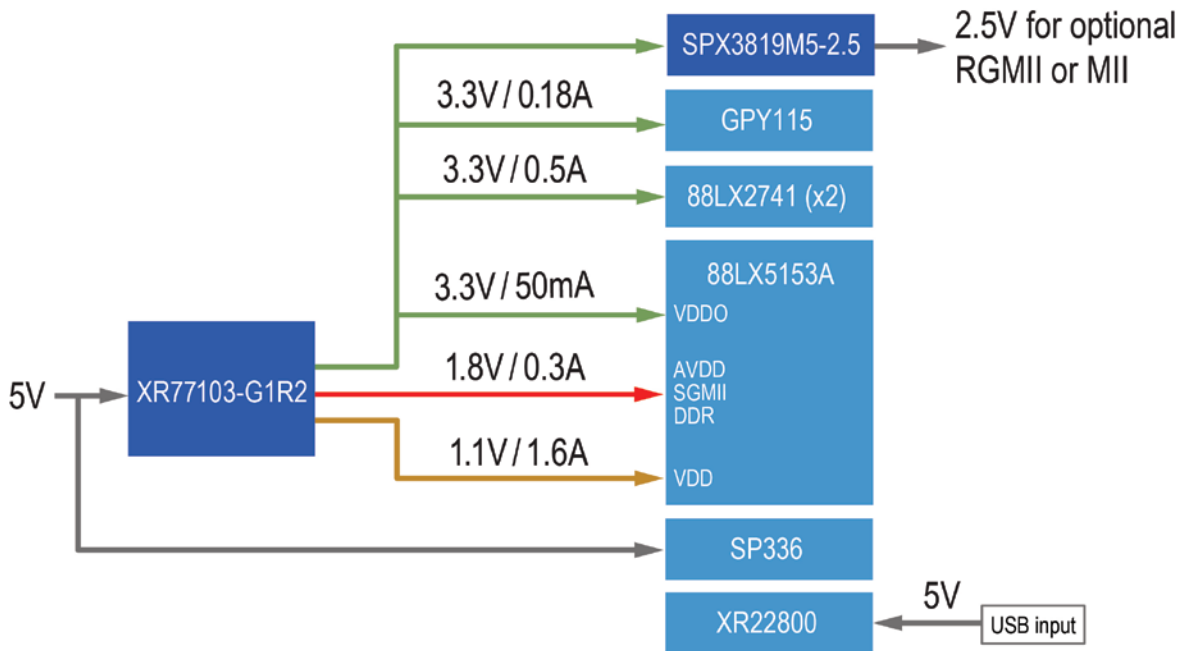

DMI920 G.hn Industrial Multi-Medium, Multi-Interface IIoT EVK

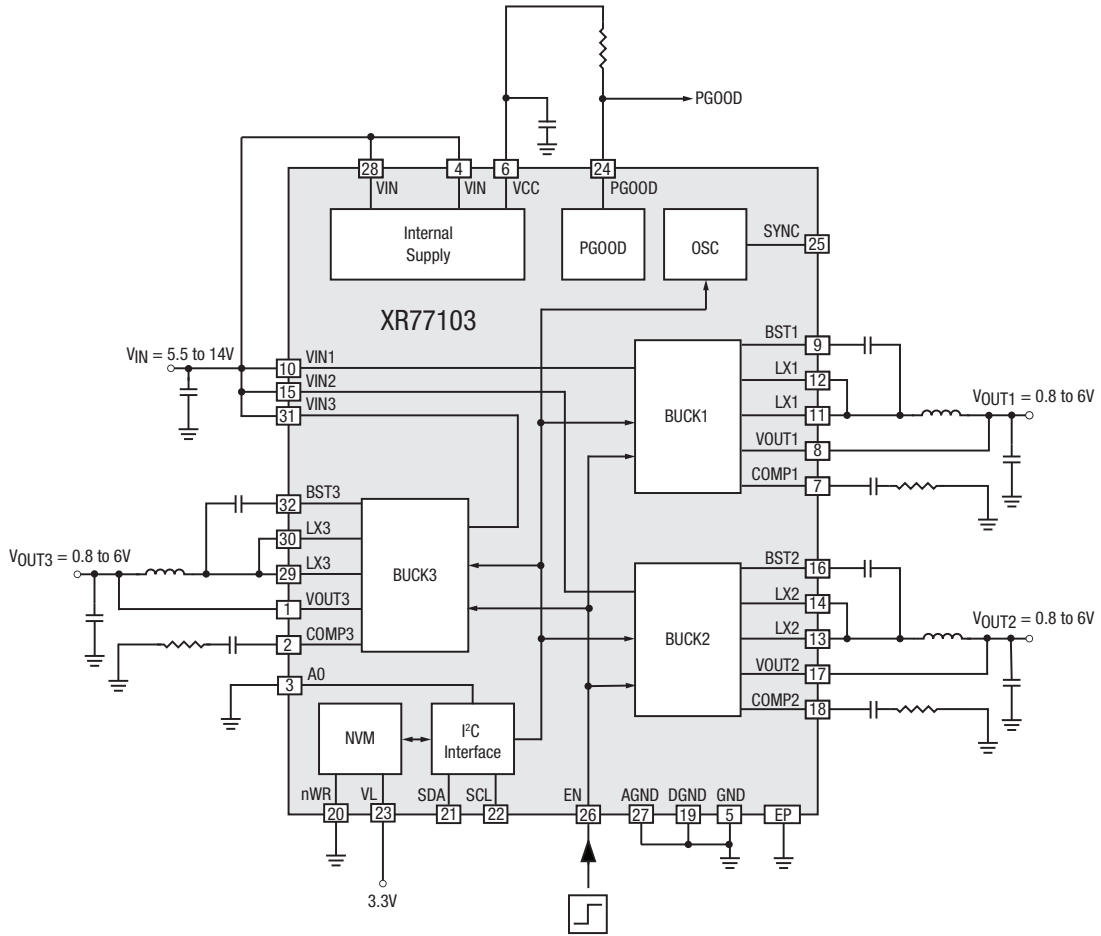

**Universal PMIC 3-Output Programmable Buck Regulator Typical Application**

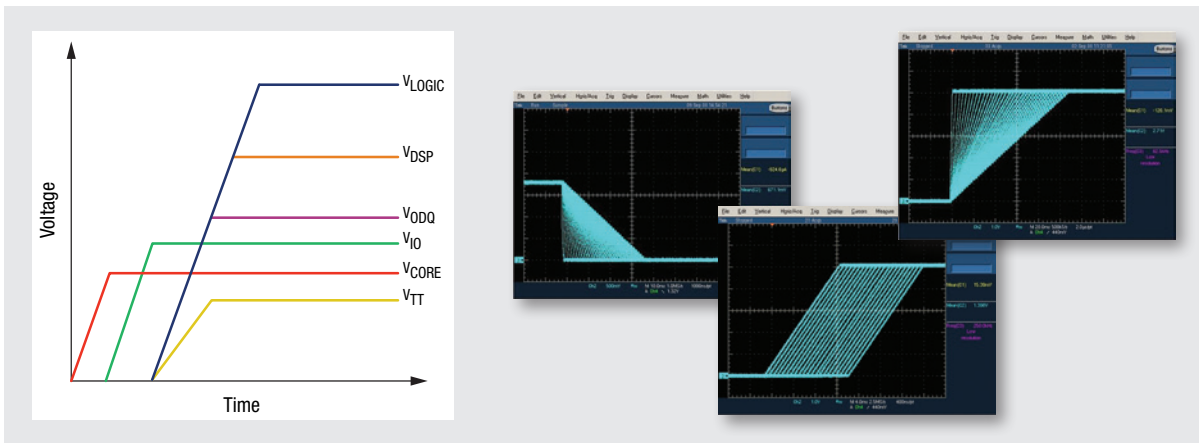

**Control Power Up/Down Sequencing with Different Delays and Slopes using PowerArchitect™**

## Power Modules

MaxLinear's power modules address high-current solutions for various end applications. These synchronous step-down power modules are complete system-in-package power management solutions with fully integrated power converters including MOSFETs, inductors and internal input and output capacitors. Our XR79xxx modules utilize a patented emulated current mode Constant On-Time (COT) control that provides exceptional full range 0.1% line regulation and 1% output accuracy over the full temperature range. This COT control loop enables operation with ceramic output capacitors, eliminating loop compensation components.

Our QFN modules provide superior thermal performance and manufacturability, all in the smallest footprint. The QFN package makes visual inspection of solder joints possible and eases electrical debugging. At 85°C with no airflow, no thermal de-ratings are required for output voltages of 1.8V and below.

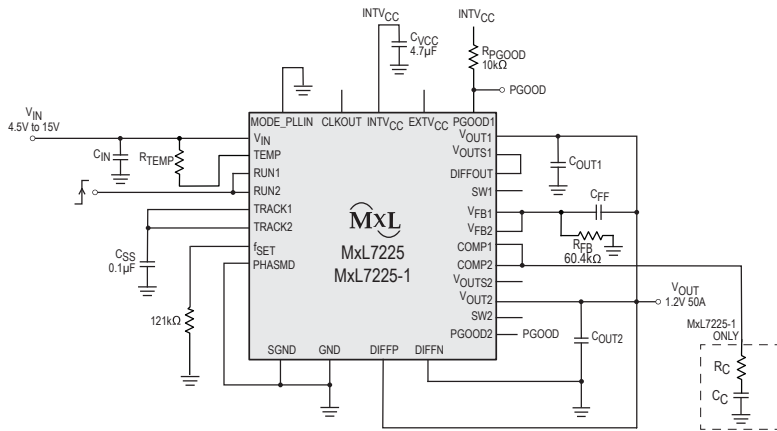
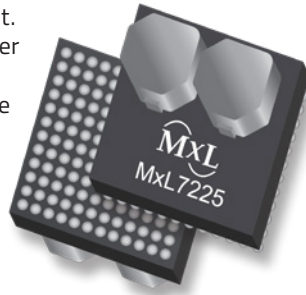

Typical Application

### Applications

- FPGA, DSP and ASIC power systems
- Base stations
- Repeaters
- Networking
- Telecommunications
- Industrial and embedded systems

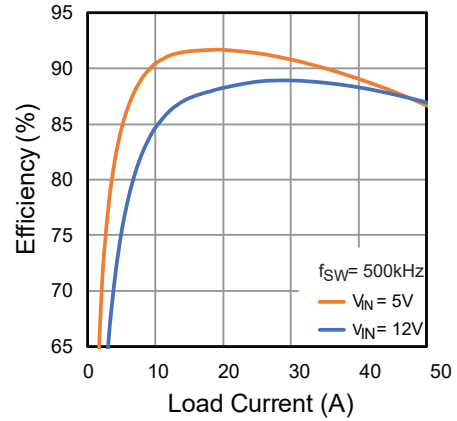

MxL7225 Efficiency 12VIN

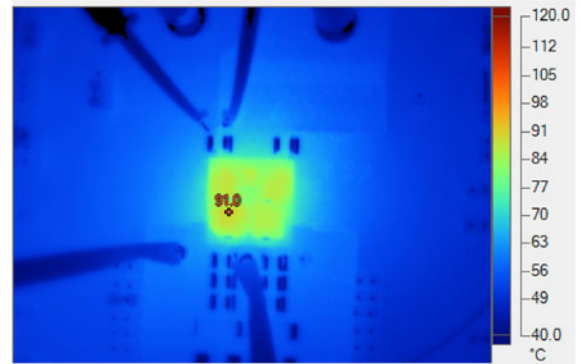

MxL7225 Thermal Image

Part Number	Ch.	Output Current (A)	V <sub>IN</sub> Range (V)	V <sub>OUT</sub> Range (V)	Frequency (kHz)	Efficiency (%)	X-Y Dimension (mm)	Z Dimension (mm)	Package	Features
XR79203	1	3	3 to 40	0.6 to 13.2	400 to 800	95	8 x 8	4	QFN	<ul style="list-style-type: none"> <li>▪ Patented COT control</li> <li>▪ UVLO, OTP, soft-start, adjustable hiccup current limit and short-circuit protection</li> <li>▪ PGGOOD</li> </ul>
XR79206		6	3 to 40	0.6 to 13.2	400 to 800	95	10 x 10			
XR79103		3	3 to 22	0.6 to 5.5	600 to 800	95	6 x 6			
XR79106		6	3 to 22	0.6 to 5.5	600 to 800	95	8 x 8			
XR79110		10	3 to 22	0.6 to 5.5	400 to 800	96	10 x 10			
XR79115		15	3 to 22	0.6 to 5.5	400 to 600	96	12 x 12			
XR79120		20	3 to 22	0.6 to 5.5	400 to 600	93	12 x 14			
MxL7218	2	18	4.5 to 15	0.6 to 1.8	400 to 780	95	16 x 16	5.01	BGA	<ul style="list-style-type: none"> <li>▪ PFM</li> <li>▪ Adjustable frequency and soft start</li> <li>▪ UVLO, OTP, and over current/over voltage/short-circuit protection</li> </ul>
MxL7225/ MxL7225-1	2	25	4.5 to 15	0.6 to 1.8	400 to 780	93	16 x 16	5.01	BGA	<ul style="list-style-type: none"> <li>▪ Frequency synchronization</li> <li>▪ PGGOOD</li> </ul>



Power Solutions for MaxLinear SoCs

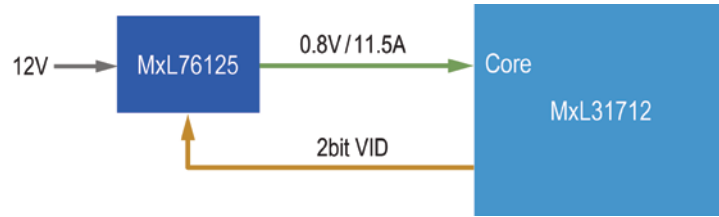

MxL31712/08 Wi-Fi 7 SoC Core Power Solution

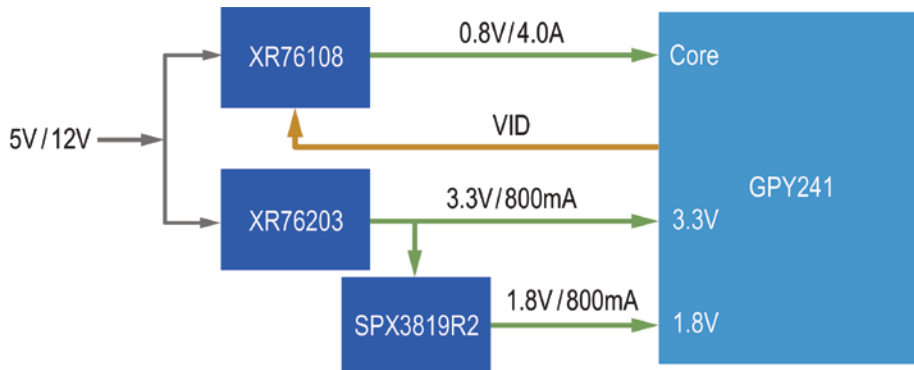

GPY241/245 Quad 2.5Gb Ethernet PHY Power Solution

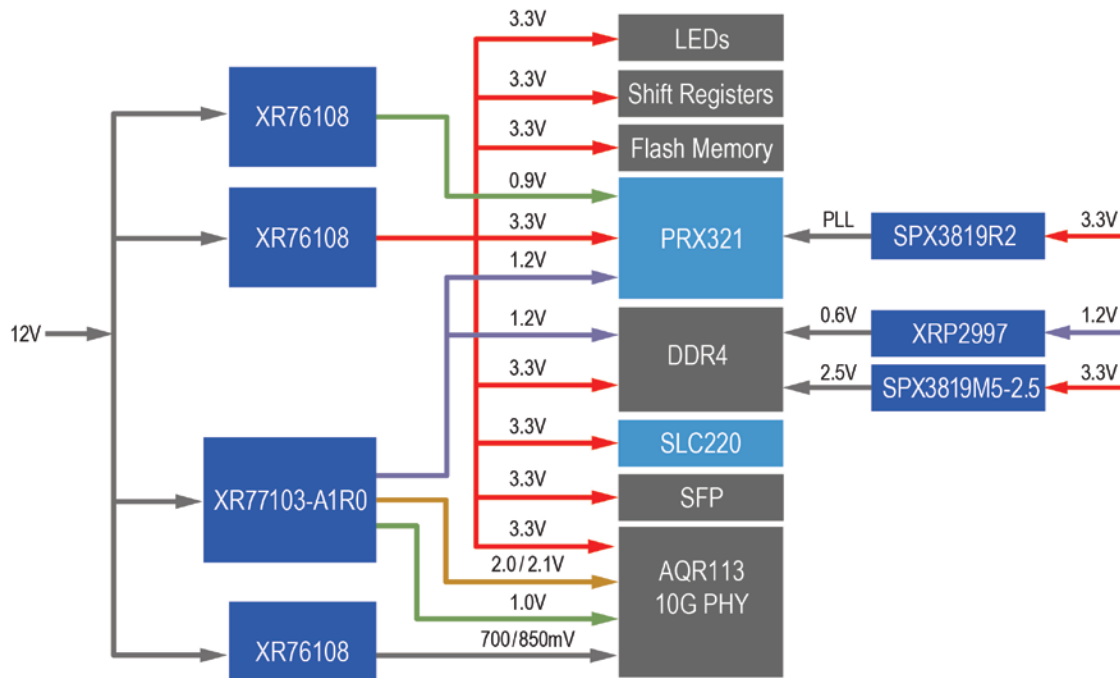

XGSPON Power Solution with PRX321 10G PON SoC and SLC220 Dual-Channel SLIC

Step-Down Switching Regulators

MaxLinear’s family of synchronous and non-synchronous step-down regulators provides a fully integrated single-chip solution for Point-of-Load (POL) applications with high current output requirements. With high input voltage range and operating switching frequency options, these regulators fit in a wide range of applications and power architectures by enabling step-down DC/DC conversions from various intermediate power bus levels and providing a highly efficient and high performing solution in the most compact footprint.

Applications

- Home Gateways and Routers (CPE)
- Point-of-Load (POL) converters
- Point-of-Load (POL) modules
- FPGAs, DSPs and processor power supplies

Part Number	Output Current (A)	Frequency (kHz)	Operating Voltage (V)		Output Voltage	Output Voltage Range (V)		Accuracy (%)	Efficiency (%)	Package (mm)	Features
			Min	Max		Min	Max				
XR76203	3	100 to 800	3	40	Adj.	0.6	30	0.5	95	5 x 5 QFN	<ul style="list-style-type: none"> <li>▪ Patented COT control</li> <li>▪ UVLO, OTP, soft-start, hiccup, PGOOD</li> <li>▪ Current limit and short protection</li> </ul>
XR76205	5								96		
XR76208	8								96		
SP7650	3	300	2.5	28	Adj.	0.8	27	1	95	7 x 4 DFN	<ul style="list-style-type: none"> <li>▪ Synchronous</li> <li>▪ UVLO, OTP, soft-start</li> <li>▪ Short-circuit protection/auto-restart</li> </ul>
XR76108	8	200 to 800	3	22	Adj.	0.6	18	0.5	96	5 x 5 QFN	<ul style="list-style-type: none"> <li>▪ Patented COT control</li> <li>▪ UVLO, OTP, soft-start, hiccup, PGOOD</li> <li>▪ Current limit and short protection</li> </ul>
XR76112	12										
XR76117	15	200 to 800	4.5	22	Adj.	0.6	18	0.5	97	5 x 6 QFN	<ul style="list-style-type: none"> <li>▪ Patented COT control</li> <li>▪ UVLO, OTP, soft-start, hiccup, PGOOD</li> <li>▪ Current limit and short protection</li> </ul>
XR76121	20	200 to 800	4.5	22	Adj.	0.6	18	0.5	97	5 x 6 QFN	
MxL76125	15	200 to 1250	1	22	Adj.	0.6	18	800	96	QFN-23	<ul style="list-style-type: none"> <li>▪ Patented COT control</li> <li>▪ 2-BIT VID</li> <li>▪ UVLO, OTP, soft-start, hiccup, PGOOD</li> <li>▪ Current limit and short protection</li> </ul>
SP6669	0.6	1500	2.5	5.5	Adj.	0.6	5	2.0	95	SOT23-5	<ul style="list-style-type: none"> <li>▪ Synchronous</li> <li>▪ Enable pin</li> <li>▪ Pulse skipping at light load</li> <li>▪ Over temperature protection</li> </ul>
XRP6658	1	1500	2.5	5.5	Adj.	0.6	5	<3.0	97	SOT23-5	<ul style="list-style-type: none"> <li>▪ Synchronous</li> <li>▪ Light load efficiency, PFM and PWM mode</li> <li>▪ Enable pin</li> <li>▪ UVLO and over temperature protection</li> </ul>

## Switching Controllers

Switching controllers, also known as buck controllers or Step-down, are the basic building blocks for high efficiency and high power point-of-loads. Step-down controllers allow maximum flexibility and customization for high performance conversions.

### Applications

- Distributed power architectures
- Point-of-Load (POL) converters/modules
- Set-top boxes

Part Number	Rec. Output Current (A)	Operating Voltage (V)		Min. Output Voltage (V)	Quiescent Current ( $\mu$ A)	Frequency (kHz)	Efficiency (%)	Package	Features
		Min	Max						
XR75100	<20	3	40	0.6	700	200 to 800	96	QFN-16	<ul style="list-style-type: none"> <li>▪ Proprietary emulated current mode constant on-time architecture</li> <li>▪ No external compensation</li> <li>▪ Adjustable frequency</li> <li>▪ Precision enable, soft-start, force PWM</li> <li>▪ Adjustable temperature compensated current limit</li> </ul>
XRP6124HV	<5	4.5	30	1.2	500	200 to 1000	92	SOT23-5	<ul style="list-style-type: none"> <li>▪ Non synchronous, 500ns constant on-time</li> <li>▪ Enable pin, soft-start</li> <li>▪ UVLO and output short-circuit protection</li> </ul>
SP6134H	<15	3	28	0.8	1.5mA	600	94	MSOP-10	<ul style="list-style-type: none"> <li>▪ Synchronous voltage mode PWM</li> <li>▪ Programmable soft-start</li> <li>▪ UVLO, over temperature and output short-circuit protection</li> </ul>
SP6132H	<20	3	28			300	95		
XRP6141	<35	3	22	0.6	700	200 to 800	95	QFN-16	<ul style="list-style-type: none"> <li>▪ Proprietary emulated current mode constant on-time architecture</li> <li>▪ No external compensation</li> <li>▪ Adjustable frequency</li> <li>▪ Precision enable, soft-start, force PWM</li> <li>▪ Adjustable temperature compensated current limit</li> </ul>

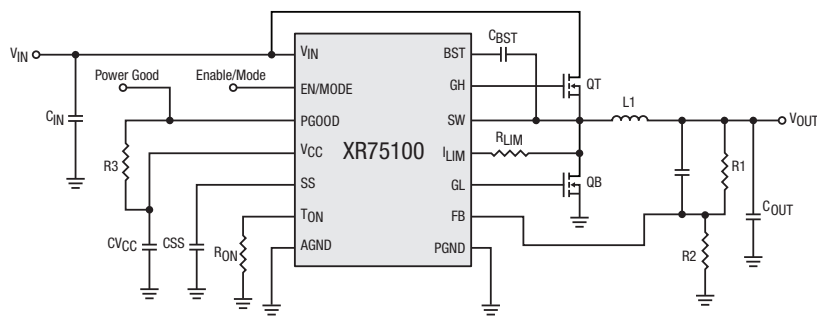

40V Synchronous Step-Down COT Controller

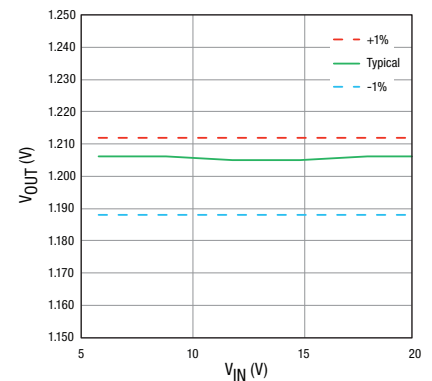

XR75100 Line Regulation

DDR Termination

Part Number	Output Current	Output Voltage	Accuracy (%)	Operating Voltage (V)		Quiescent Current (μA)	Package	Features
				Min	Max			
XRP2997	2A	Adjustable	1	1.1	5.5	2	HSOIC-8	<ul style="list-style-type: none"> <li>DDR I/II/III/IV bus termination</li> <li>Over temperature protection</li> <li>Overcurrent protection</li> </ul>

LDOs & Linear Regulators

Maxlinear manufactures a broad line of low dropout linear regulators (LDO). The simplest and lowest cost technique for stepping down a DC voltage, LDOs offer a quiet, well-regulated DC voltage supply with excellent transient response.

Applications

- Portable equipment
- Handheld devices
- Mobile phones and PDAs
- Medical and industrial instrumentation

Part Number	Output Current	Output Voltage (V)	V <sub>OUT</sub> (V) Adjustable		Accuracy (%)	Typical Dropout Voltage (mV)	Operating Voltage (V)		Quiescent Current (μA)	Package	Features
			Min	Max			Min	Max			
SP6213	100mA	3.3			2.5	250	2.5	7	65	SC70-5	<ul style="list-style-type: none"> <li>Enable pin</li> <li>Current limiting and thermal protection</li> </ul>
LP2951	100mA	3.3, 5			0.5, 1	380	2.4	30	150	NSOIC-8	<ul style="list-style-type: none"> <li>Enable pin</li> <li>Output error flag indicator</li> <li>Current limiting and thermal protection</li> </ul>
SPX5205	150mA	Adj., 1.8, 3, 3.3, 5	1.24	15.725	1	210	2.5	16	70	SOT23-5	<ul style="list-style-type: none"> <li>Reverse battery protection</li> <li>Current limiting and thermal protection</li> </ul>
SPX2954	250mA	5			0.5	310	2.4	30	150	SOT223-3	<ul style="list-style-type: none"> <li>Enable pin</li> <li>Output error flag indicator</li> <li>Current limiting and thermal protection</li> </ul>
		3.3, 5			1					SOT223-3	
SPX2945	400mA	3.3			0.5, 1	420	4.1	30	100	SOT223-3	<ul style="list-style-type: none"> <li>Enable pin</li> <li>Output error flag indicator</li> <li>Current limiting and thermal protection</li> </ul>
SP6205	500mA	Adj., 3, 3.3	2.7	5.7	2	300	2.7	6	45	SOT23-5	<ul style="list-style-type: none"> <li>Low noise: 12μV<sub>RMS</sub> (fixed voltage version)</li> <li>Enable pin</li> <li>Current limiting</li> <li>Over temperature protection</li> </ul>
		Adj.								DFN-8	
SPX3819	500mA	Adj., 1.2, 1.5, 1.8, 2.5, 3, 3.3, 5	1.235	15.45	1	340	2.5	16	90	SOT23-5	<ul style="list-style-type: none"> <li>Enable pin</li> <li>Reverse battery protection</li> <li>Current limiting and thermal protection</li> </ul>
		Adj., 1.2								DFN-8	
		Adj., 5								NSOIC-8	
SPX1117	800mA	Adj., 1.5, 1.8, 2.5, 3.3, 5	1.25	15	1	1100	2.6	15	5mA	SOT223-3	<ul style="list-style-type: none"> <li>Current limiting and thermal protection</li> </ul>
SPX2941	1A	Adj.	1.24	15.45	3	280	3	16	12mA	TO263-5	<ul style="list-style-type: none"> <li>Enable pin</li> <li>Reverse battery protection</li> <li>Current limiting and thermal protection</li> </ul>

Part Number	Output Current	Output Voltage (V)	V <sub>OUT</sub> (V) Adjustable		Accuracy (%)	Typical Dropout Voltage (mV)	Operating Voltage (V)		Quiescent Current (μA)	Package	Features			
			Min	Max			Min	Max						
SPX3940A	1A	3.3, 5			1	280	3.1	16	18mA	SOT223-3	<ul style="list-style-type: none"> <li>Reverse battery protection</li> <li>Current limiting and thermal protection</li> </ul>			
		3.3											TO263-3	
SPX3940		2.5, 5			2									SOT223-3
		3.3											TO263-3	
SPX2815	1.5A	Adj.	1.25	8.8	1, 2	1100	2.5	10	4mA	TO263-3	<ul style="list-style-type: none"> <li>Current limiting and thermal protection</li> </ul>			
SPX29152	1.5A	Adj.	1.25	15.4	1	390	2.5	16	12mA	TO263-5	<ul style="list-style-type: none"> <li>Enable pin</li> <li>Current limiting and thermal protection</li> </ul>			
XRP6272	2A	Adj., 5	0.7	5.3	2	550	1.8	6	30	TO252-5 HSOIC-8	<ul style="list-style-type: none"> <li>Enable and power good functions</li> <li>Current limiting and thermal protection</li> </ul>			
SPX1582	3A	Adj.	1.25	6	2	400	1.8	5.5	5mA	TO263-5	<ul style="list-style-type: none"> <li>Enable pin</li> <li>External sense pin</li> <li>Current limiting and thermal protection</li> </ul>			
SPX1587	3A	Adj., 3.3	1.25	8.8	1	1100	2.8	10	4mA	TO263-3	<ul style="list-style-type: none"> <li>Current limiting</li> <li>Over temperature protection</li> </ul>			
SPX29300	3A	2.5, 3.3, 5			1	600	2.5	16	37mA	TO263-3	<ul style="list-style-type: none"> <li>Current limiting and thermal protection</li> <li>Reverse battery protection</li> </ul>			
SPX29301	3A	5			1	600	4	16	37mA	TO263-5	<ul style="list-style-type: none"> <li>Enable pin</li> <li>Output error flag indicator</li> <li>Current limiting and thermal protection</li> </ul>			
SPX29302/ XRP29302	3A	Adj.	1.25	16	1	600	2.8	16	37mA	TO263-5	<ul style="list-style-type: none"> <li>Enable pin</li> <li>Current limiting and thermal protection</li> <li>Reverse battery protection</li> </ul>			
SPX1585	5A	Adj.	1.2	8.8	1	1100	2.8	10	5mA	TO-263-3	<ul style="list-style-type: none"> <li>Current limiting and thermal protection</li> </ul>			

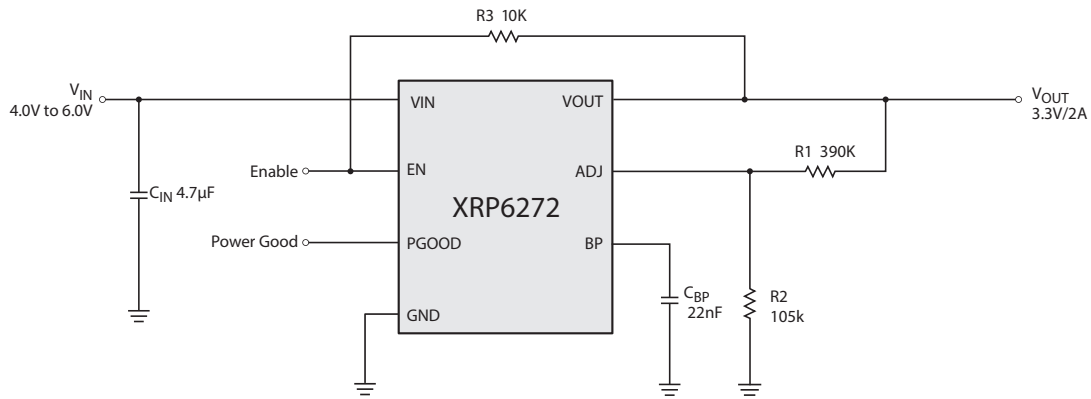

**XRP6272 Typical Application**



## Power Switches

Power switches provide low loss, high efficiency power management, monitoring and fault handling capabilities for any power distribution network. Use of these compact devices results in safer, more stable and more reliable interconnecting systems.

### Applications

- USB  $V_{BUS}$  power management
- Set-top boxes
- USB peripherals
- Battery charger circuits

Part Number	Channel(s)	Output Current	Current Limit	Operating Voltage (V)		Quiescent Current ( $\mu$ A)	Package	Features
				Min	Max			
SP2525A	1	500mA	850mA	3	5.5	75	NSOIC-8	<ul style="list-style-type: none"> <li>▪ Active high or low enable pin(s)</li> <li>▪ USB 2.0 compliant</li> <li>▪ Current limiting</li> </ul>
SP2526A	2	500mA	850mA	3	5.5	110	NSOIC-8	<ul style="list-style-type: none"> <li>▪ Fault flag indicator(s)</li> <li>▪ Over temperature protection</li> <li>▪ Undervoltage lock out protection</li> </ul>

## Voltage References

Voltage references provide a precise and stable output voltage over a wide range of conditions such as input voltage fluctuations and/or operating temperature change. These devices guarantee system accuracy and performance.

### Applications

- Power supplies
- Mother boards
- Medical and industrial instrumentation

Part Number	$V_{REF}$ (V)	Accuracy (%)	Operating Current (mA)	Max Operating Voltage (V)	$I_{REF}$ ( $\mu$ A)	Operating Temperature Range ( $^{\circ}$ C)	Temperature Coefficient (ppm/ $^{\circ}$ C)	Package	Features
SPX385	2.5	1	0.01 to 20	–	–	-40 to 85	80	SOT23-3	<ul style="list-style-type: none"> <li>▪ Shunt reference</li> <li>▪ Replacement for LM285/385</li> </ul>
SPX432	1.24	1	1 to 80	15	3	0 to 105	50	SOT23-3	<ul style="list-style-type: none"> <li>▪ <math>V_{REF}</math> adjustable to 15V</li> <li>▪ Replaces TLV431 and AS432</li> </ul>
SPX1431	2.5	0.4	1 to 150	36	0.7	-55 to 125	30	SOT89-3	<ul style="list-style-type: none"> <li>▪ <math>V_{REF}</math> adjustable up to 36V</li> <li>▪ Replaces TL1431</li> </ul>
SPX2431	2.5	0.5, 1	1 to 100	20	0.7	0 to 105	30	SOT23-3	<ul style="list-style-type: none"> <li>▪ <math>V_{REF}</math> adjustable up to 20V</li> <li>▪ Replaces TL2431 and AS2431</li> </ul>

## Supervisors

Supervisory circuits ensure safe operating conditions for microprocessor and memory-based systems. By monitoring one or more system supplies, supervisory circuits provide basic protection such as power-on reset as well as fault monitoring during power-up, power down and undervoltage (brownout) conditions. Additional functions typically include a watchdog timer, a manual reset and battery backup supply switching.

### Applications

- **Mother boards**
- **Telecom and datacom equipment**
- **Medical and industrial instrumentation**

Part Number	Channel(s)	Reset Threshold (V)	Reset Accuracy	Reset Active	Operating Voltage(V)		Quiescent Current (µA)	Package	Features
					Min	Max			
SP691A	1	4.65	125mV	Low/High	1	5.5	35	NSOIC-16 WSOIC-16	<ul style="list-style-type: none"> <li>▪ Programmable watchdog timer</li> <li>▪ Back-up battery switchover</li> <li>▪ Power fail, low battery indicator</li> <li>▪ Chip enable gating</li> </ul>
SP705	1	4.65	150mV	Low	1.1	5.5	40	NSOIC-8	<ul style="list-style-type: none"> <li>▪ Watchdog timer</li> <li>▪ Power fail, low battery indicator</li> <li>▪ Manual reset</li> </ul>
SP706	1	4.40	150mV	Low	1.1	5.5	40	NSOIC-8	<ul style="list-style-type: none"> <li>▪ Watchdog timer</li> <li>▪ Power fail, low battery indicator</li> <li>▪ Manual reset</li> </ul>
SP706R	1	2.63	80mV	Low	1.1	5.5	25	NSOIC-8	<ul style="list-style-type: none"> <li>▪ Watchdog timer</li> <li>▪ Power fail, low battery indicator</li> <li>▪ Manual reset</li> </ul>
SP706S	1	2.93	80mV	Low	1.1	5.5	25	NSOIC-8 MSOP-8	<ul style="list-style-type: none"> <li>▪ Watchdog timer</li> <li>▪ Power fail, low battery indicator</li> <li>▪ Manual reset</li> </ul>
SP706T	1	3.08	80mV	Low	1.1	5.5	25	NSOIC-8 MSOP-8	<ul style="list-style-type: none"> <li>▪ Watchdog timer</li> <li>▪ Power fail, low battery indicator</li> <li>▪ Manual reset</li> </ul>
SP707	1	4.65	150mV	Low/High	1.1	5.5	40	NSOIC-8	<ul style="list-style-type: none"> <li>▪ Power fail, low battery indicator</li> <li>▪ Manual reset</li> </ul>
SP708	1	4.40	150mV	Low/High	1.1	5.5	40	NSOIC-8	<ul style="list-style-type: none"> <li>▪ Power fail, low battery indicator</li> <li>▪ Manual reset</li> </ul>
SP708S	1	2.93	80mV	Low/High	1.1	5.5	25	NSOIC-8 MSOP-8	<ul style="list-style-type: none"> <li>▪ Power fail, low battery indicator</li> <li>▪ Manual reset</li> </ul>
SP708T	1	3.08	80mV	Low/High	1.1	5.5	25	NSOIC-8	<ul style="list-style-type: none"> <li>▪ Power fail, low battery indicator</li> <li>▪ Manual reset</li> </ul>
SP809	1	2.3, 2.6, 2.9	1.50%	Low	0.9	6	1	SOT23-3	<ul style="list-style-type: none"> <li>▪ 140ms reset pulse width</li> <li>▪ Push-pull output</li> </ul>
SP813L	1	4.65	150mV	High	1.1	5.5	40	NSOIC-8	<ul style="list-style-type: none"> <li>▪ Watchdog timer</li> <li>▪ Manual reset</li> </ul>

## Switching Regulators

Efficiency, performance, size and reliability are rapidly imposing LEDs as the lighting solution of choice in space-constrained portable electronic equipment as well as in architectural and accent lighting fixtures. Maxlinear's LED lighting products offer compact and efficient solutions for line and battery-operated devices and are capable of driving multiple LEDs in various series or parallel topologies.

### Applications

- General lighting and display
- Medical and industrial instrumentation
- Keypad and signage backlighting

Part Number	Ch.	Max Current/ Ch.	LEDs/ Ch.	Operating Voltage (V)		Ref. Voltage (mV)	Freq. (MHz)	Max Output Voltage (V)	Quiescent Current ( $\mu$ A)	Efficiency (%)	Package	Application	Features
				Min	Max								
XRP7613	1	1.2A	8	7	36	100	<1	36	35	95	SOIC-8	High-powered LED	<ul style="list-style-type: none"> <li>▪ Hysteretic PFM control</li> <li>▪ Enable and soft-start functions</li> <li>▪ Analog and PWM dimming</li> <li>▪ Dynamic LED current thermal control</li> </ul>

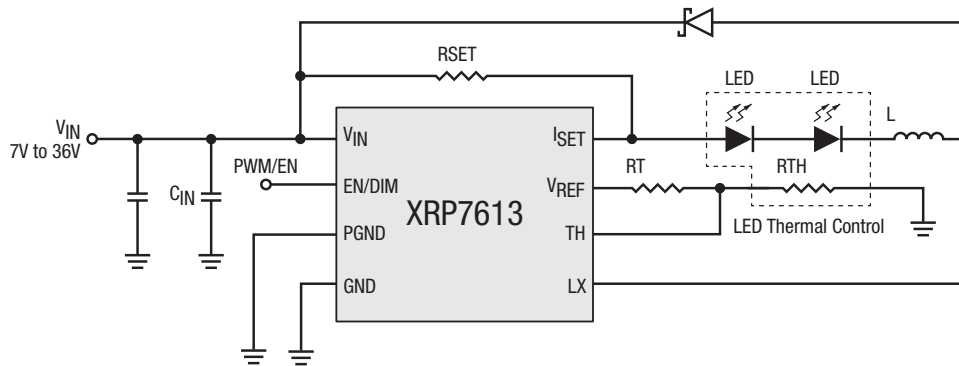

1.2A 36V Step-Down LED Driver

The content of this document is furnished for informational use only, is subject to change without notice, and should not be construed as a commitment by MaxLinear, Inc. MaxLinear, Inc. assumes no responsibility or liability for any errors or inaccuracies that may appear in the informational content contained in this guide. Complying with all applicable copyright laws is the responsibility of the user. Without limiting the rights under copyright, no part of this document may be reproduced into, stored in, or introduced into a retrieval system, or transmitted in any form or by any means (electronic, mechanical, photocopying, recording, or otherwise), or for any purpose, without the express written permission of MaxLinear, Inc.

EXCEPT AS OTHERWISE PROVIDED EXPRESSLY IN WRITING BY MAXLINEAR, AND TO THE MAXIMUM EXTENT PERMITTED BY LAW: (A) THE MAXLINEAR PRODUCTS ARE PROVIDED ON AN "AS IS" BASIS WITHOUT REPRESENTATIONS OR WARRANTIES OF ANY KIND, INCLUDING WITHOUT LIMITATION ANY IMPLIED OR STATUTORY WARRANTIES AND ANY WARRANTIES OF MERCHANTABILITY, FITNESS FOR A PARTICULAR PURPOSE, NON-INFRINGEMENT, OR TITLE; AND (B) MAXLINEAR DOES NOT GUARANTEE THAT THE PRODUCTS WILL BE FREE OF ERRORS OR DEFECTS. MAXLINEAR PRODUCTS SHOULD NOT BE USED IN ANY EMERGENCY, SECURITY, MILITARY, LIFE-SAVING, OR OTHER CRITICAL USE CASE WHERE A FAILURE OR MALFUNCTION COULD CAUSE PERSONAL INJURY OR DEATH, OR DAMAGE TO OR LOSS OF PROPERTY. USERS ASSUME ALL RISK FOR USING THE MAXLINEAR PRODUCTS IN SUCH USE CASE. CUSTOMERS AND USERS ARE SOLELY RESPONSIBLE FOR USING THEIR OWN SKILL AND JUDGMENT TO DETERMINE WHETHER MAXLINEAR PRODUCTS ARE SUITABLE FOR THE INTENDED USE CASE.

MaxLinear, Inc. may have patents, patent applications, trademarks, copyrights, or other intellectual property rights covering subject matter in this document. Except as expressly provided in any written license agreement from MaxLinear, Inc., the furnishing of this document does not give you any license to these patents, trademarks, copyrights, or other intellectual property.

MaxLinear, the MaxLinear logo, any other MaxLinear trademarks (including but not limited to MxL, Full-Spectrum Capture, FSC, AirPHY, Puma, AnyWAN, VectorBoost, MXL WARE, and Panther), and the MaxLinear logo on the products sold are all property of MaxLinear, Inc. or one of MaxLinear's subsidiaries in the U.S.A. and other countries. All rights reserved.

All third-party product, company names and logos are trademarks™ or registered® trademarks and remain the property of their respective holders/owners. Use of such marks does not imply any affiliation with, sponsorship or endorsement by the owners/holders of such trademarks. All references by MaxLinear to third party trademarks are intended to constitute nominative fair use under applicable trademark laws.

The URLs provided are for informational purposes only; they do not constitute an endorsement or an approval by MaxLinear of any of the products or services of the corporation or organization or individual. MaxLinear bears no responsibility for the accuracy, legality or content of the external site or for that of subsequent links. Contact the external site for answers to questions regarding its content.



**Corporate Headquarters:**  
5966 La Place Court  
Suite 100  
Carlsbad, CA 92008  
Tel.: +1 (760) 692-0711  
Fax: +1 (760) 444-8598  
[www.maxlinear.com](http://www.maxlinear.com)